

PNEUMATIC TYPE STAINLESS KNIFE GATE VALVE

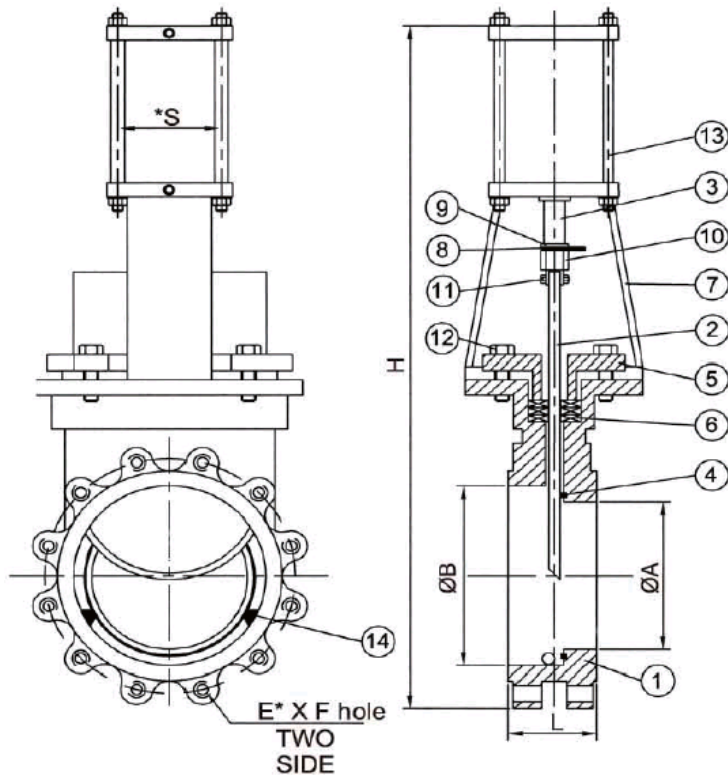

CONNECTION RATING:  
 JIS 5K JIS 10K JIS7.5K  
 ANSI 150#  
 DIN PN10 PN16



MSS-SP81 TEST STANDARD:  
 BODY TEST: 11kg/cm<sup>2</sup> (WATER)  
 SEAT TEST: 2.8kg/cm<sup>2</sup> (WATER)  
 LEAKAGE: 4 cc/per in. min.

14	GUIDE	SUS304
13	ACTUATOR	ALLOY.FC
12	BOLT AND NUT	SUS304
11	CONNECTOR	SUS304
10	NUT	SUS304
9	NUT	SUS304
8	POINTER	SUS304
7	YOKE	DUCTILE IRON
6	GLAND PACKING	ASB NON-ASB
5	GLAND	SUS304
4	SEAT	TEFLON
3	STEM	SS41+HCr
2	PLATE	SUS304.316.316L
1	BODY	CF8.CF8M.CF3M
NO.	SUBJECT	MATERIAL

( FOR REFERENCE ONLY. )

DIMENSION TABLE : MM

SIZE	L	ØA	ØB	ØS	H
2"	48	42	64	63	520
2-1/2"	51	57	80	63	570
3"	51	72	95	80	680
4"	51	95	120	80	755
5"	57	125	148	125	900
6"	57	150	175	125	960
8"	70	195	222	150	1160
10"	70	250	275	180	1440
12"	76	300	325	200	1605
14"	76	350	375	250	1860
16"	89	400	430	250	2070
18"	89	435	475	250	2200
20"	114	480	515	300	2400
24"	114	580	620	300	2750

( FOR REFERENCE ONLY. )

MATERIAL:

	BODY	PLATE	SEAT	GLAND PACKING
MATERIAL	CF8	SUS304	TEFLON	NON-ASB+PTFE
	CF8M	SUS316	METAL	ASB
	CF3M	SUS304L	VITON	ASB+PTFE
		SUS316L	EPDM	TEFLON NON ASBESTOS

TEMPERATURE:

MATERIAL	TEM. RANGE
ASBESTOS+PTFE	-50° ~ 550°C
SILICON	-20° ~ 150°C
VITON	-20° ~ 250°C
TEFLON	-30° ~ 150°C
NON ASBESTOS	-50° ~ 550°C

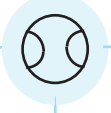

偉群國際有限公司  
新竹縣竹北市國盛街 271 號  
電話：03-555-6551 · 傳真：03-555-0352  
<http://www.wilson-co.com.tw>

Wilson-International Co.  
No.271, Guosheng St., 302-44 Zhubei City,  
Hsin Chu County, Taiwan, R.O.C.

WE SERVE. WE CARE. WHAT YOU NEED. EVERY WHERE AND EVERY TIME.